

A3	1	2	3	4	5	6	7	8
----	---	---	---	---	---	---	---	---

IF IN DOUBT ASK. DO NOT SCALE THIS DRAWING.

ISS	DATE	DRAWN	CHECKED	Rel. No.	DETAILS OF CHANGE
1	22/01/16	JS	CE	-	INITIAL ISSUE FROM 40632

A

B

C

D

E

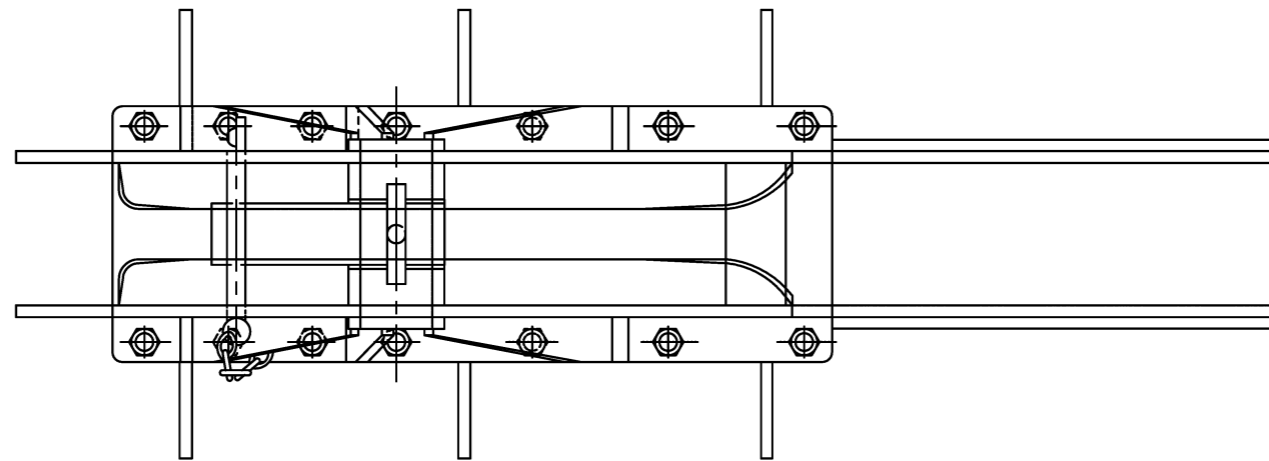
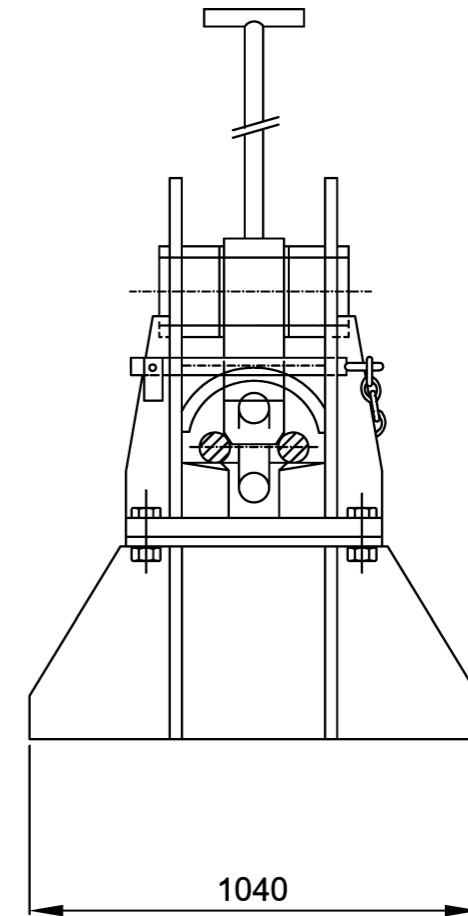
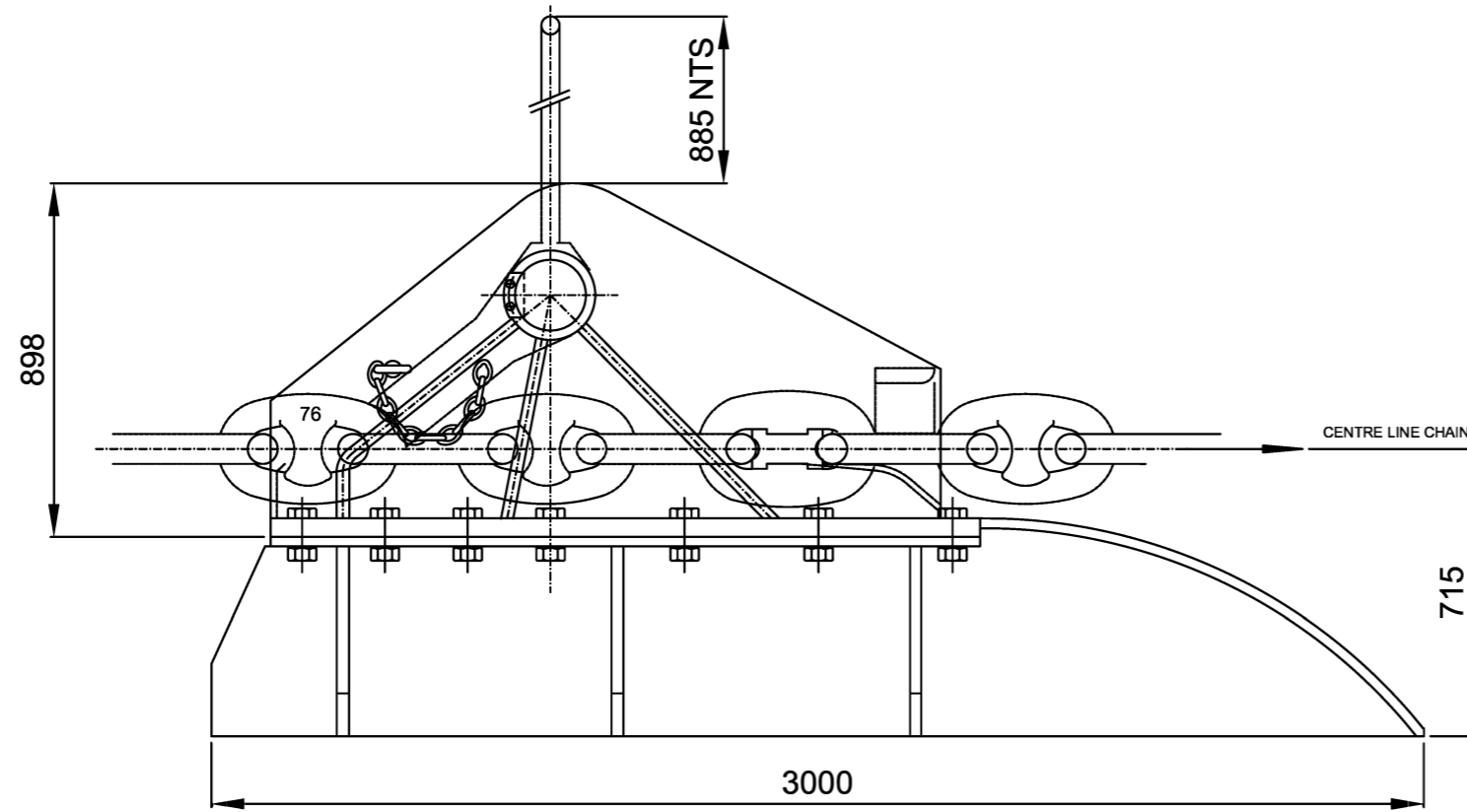

NOTES:
TO BE USED WITH 76mm CHAIN

F

F

fendercare
marine

ENTERPRISE HOUSE HARVEYS LANE
SEETHING NORFOLK NR15 1EN ENGLAND
TEL +44 1508 482691 FAX +44 1508 482710
EMAIL: sales@fendercare.com

MATERIAL	N.A.
FINISH	N.A.

THIS DRAWING MAY CALL FOR THE USE OF PROCEDURES THAT MAY BE INJURIOUS TO HEALTH IF ADEQUATE PRECAUTIONS ARE NOT TAKEN. IT REFERS ONLY TO TECHNICAL SUITABILITY AND DOES NOT ABSOLVE THE USER FROM LEGAL OBLIGATIONS RELATING TO HEALTH AND SAFETY AT ANY STAGE



SCALE	N.T.S
DATE	22/01/16
DRAWN BY	JS
CHECKED BY	CE

REMOVE BURRS AND SHARP EDGES.

ALL DIMS IN MILLIMETRES UNLESS OTHERWISE STATED

204T S.W.L CHAIN STOPPER
& PLINTH ARRANGEMENT - SALES DRAWING

SHEET	DRAWING No
1 OF 1	47782 Issue: 1
COPYRIGHT FENDERCARE LIMITED DO NOT PASS TO A THIRD PARTY	

1	2	3	4	5	6	7	8
---	---	---	---	---	---	---	---